



Astra-Glaze-SW+® is available with recycled content.

**TRENWYTH**

**Astra-Glaze-SW+®**  
glazed masonry units

the perfect solution  
for durability, moisture / mold resistance,  
easy maintenance and aesthetics.





Astra-Glaze-SW+ glazed units are lightweight or medium weight masonry units with a thermosetting glazing compound permanently molded to one or more faces. Upon request, Astra-Glaze-SW+ is available with pre-consumer recycled content.

## Astra-Glaze-SW+® advantages at a glance

- Recycled Content** Extracted, processed and manufactured regionally, Astra-Glaze-SW+ glazed masonry units contain a significant amount of pre-consumer recycled content that may contribute LEED Green Building Rating Points® to your building.
- One-Step Installation** Single trade installation of finished load-bearing or non-load-bearing walls saves time and money.
- Permanent Glazing** Astra-Glaze-SW+ is cured and heat-treated in gas-fired tunnel kilns that enable the glazed surface to become an integral part of the unit.
- Dimensional Uniformity** Glazed facings are molded individually to ensure uniformity regardless of minor variations in the unit.
  - Durability** Weather resistant and colorfast, Astra-Glaze-SW+ resists abrasion, impact, chemicals, cracking and crazing.
- Moisture / Mold Resistant** Manufactured with an integral water repellent admixture, Astra-Glaze-SW+ is ideal for high-moisture and sanitary environments.
  - Easy to Clean** The block's permanent impervious satin glazed finish with built-in protectants resists staining. The toughest dirt and stains – even graffiti – wipe off easily.
- Impervious Surface** With its tight impervious surface, Astra-Glaze-SW+ is the optimal solution for sanitary, clean room environments.
- Low Maintenance** Virtually maintenance free, the Astra-Glaze-SW+ finish will last the lifetime of your building with no refinishing.
- Colors, Shapes & Scoring Patterns** Astra-Glaze-SW+ is available in an extraordinary color palette, as well as custom colors and a wide variety of shapes and scoring patterns for maximum design flexibility.
  - Fire Protection** Astra-Glaze-SW+ offers up to a 4-hour fire rating, depending on the thickness and internal configuration of the block.
  - ADA Compliant** Astra-Glaze-SW+ is available with rounded corners and edges for ADA compliance.
- Sound-Absorbing Option** Astra-Glaze-SW+ glazed masonry units are available in Acousta-Wal® sound-absorbing units.

Visit our new Astra-Glaze-SW+ website, [www.astraglaze.com](http://www.astraglaze.com).

TRENWYTH

Astra-Glaze-SW+®  
glazed masonry units

Specifications . . . . .	AG 1
R-Values . . . . .	AG 2 – 5
ASTM Reports . . . . .	AG 6 – 7
Block Characteristics/Fire Ratings . . . . .	AG 8
Design Details . . . . .	AG 9 – 16
Mortars & Mortar Joints . . . . .	AG 17
Installation Instructions . . . . .	AG 18 – 20
Patching Units . . . . .	AG 21
Cleaning Instructions . . . . .	AG 22 – 23
Shapes & Sizes Coding System . . . . .	AG 24
Shapes & Sizes . . . . .	AG 25 – 27
Scoring Patterns . . . . .	AG 28
Frequently Asked Questions . . . . .	AG 29 – 35
Astra-Glaze-SW+® Colors . . . . .	AG 36

This page intentionally left blank

# Astra-Glaze-SW+ Specifications

## PART 1 – GENERAL

### SUBMITTAL

Submit color samples for selection from manufacturer's series. Submit product literature, certifications, test reports, full size sample(s) of each color specified or selected. Custom colors are available. Contact Trenwyth (800-233-1924) for details.

### QUALITY ASSURANCE

All glazed masonry units shall be Trenwyth Astra-Glaze-SW+ units manufactured by Trenwyth manufacturing facilities. Glazed concrete blocks manufactured in Pennsylvania shall be lightweight units conforming to ASTM C90. Glazed concrete blocks manufactured in Arizona shall be medium weight units conforming to ASTM C90. The glazed surface shall have a smooth satin-gloss finish, externally heat-polymerized cast-on facing conforming to ASTM C744-08 and all applicable Federal Specifications. All Trenwyth units are manufactured with an approved integral water repellent CMU admixture.

All Astra-Glaze-SW+ are manufactured with pre-consumer recycled material. Contact Trenwyth (800-233-1924) for details..

**Fire Resistance:** Fire rated for up to 4 hours. Define hourly ratings required by NCMA TEK Notes, available at [www.trenwyth.com](http://www.trenwyth.com).

**Field Constructed Mock-ups:** Construct a sample panel, no less than 4' x 4', of units of each color and size to be used in the project.

A full size unit is required to illustrate color and texture for approval. Manufacturer requires that a sample panel be installed at the jobsite prior to installation of any Trenwyth product. This panel will represent both the quality of the product and the workmanship to be expected for the project. The panel must be approved by either the owner or architect for the project. Manufacturer will provide 4" units for a 4' by 4' sample panel at no cost for the material (excluding freight to site).

### DELIVERY, STORAGE AND HANDLING

Glazed masonry units shall be delivered to the jobsite on banded pallets with individual protective covers on each glazed block face. Keep protective block covers on the blocks until installation. Store pallets in single stacks on level ground and cover with waterproof covering (e.g., tarpaulins) to protect the blocks from inclement weather. Handle blocks carefully to avoid breakage and damage to the finished surface.

### PROJECT SITE CONDITIONS

**Protection of Work:** Cover walls each day after installation to keep open walls protected and dry. After units are installed they should be protected from damage by other trades performing operations that can stain or otherwise damage the finished surfaces by covering walls with plastic. Corners should be protected from damage after installation by covering them with plywood.

## PART 2– PRODUCTS

### PRODUCT NAME

Astra-Glaze-SW+® glazed concrete masonry units

### MANUFACTURER

Anchor Concrete Products (800) 233-1924  
One Connelly Road • Emigsville, PA 17318

Superlite Block (800) 331-9823  
4626 N. 42nd Avenue • Phoenix, AZ 85019

### RELATED MATERIALS

Colored matching or contrasting mortar is available from manufacturer. Consult NCMA TEK Notes, available at [www.trenwyth.com](http://www.trenwyth.com), for mortar type and specifications. Use manufacturer-approved matching water-repellent mortar additive, following manufacturer's instructions, in all exterior mortar. Consult manufacturer for recommendations.

In areas that are exposed to excessive moisture, we recommend joints to be raked and filled with BONSAL B-7000 EPOXY. See Mortar Bedding and Jointing for details.

### SIZES AND SHAPES

Actual facing dimensions shall be 7-3/4" x 15-3/4" forming a 1/16" lip around the edges of a modular 7-5/8" x 15-5/8" block. Nominal 2", 4", 6", 8", 10" and 12" standard block thickness shall be used as required, as well as standard and special block shapes. Basic units may include stretchers, jambs, caps and cove bases. Other possible face dimensions are nominal 16" x 16", 12" x 12", 8" x 18", 4" x 16", 8" x 8". Semi-solid and solid units shall be used where specified and/or shown on the drawings.

### MASONRY CLEANERS

Carefully following the manufacturer's instructions, use Custom Burnished Masonry Cleaner by PROSOCO (dilute 1 part to 3 parts clean water). Available from manufacturer. Do not powerwash.

**CAUTION!** The following solvents must never be used as they may damage Astra-Glaze-SW+ block facings: paint remover, lacquer thinner, epoxy thinner, methylene chloride, acetone, muriatic acid. Contact your Trenwyth representative for recommendations for hard to clean areas.

## PART 3 – EXECUTION

### LAYING MASONRY WALLS

Draw blocks from more than one pallet at a time during installation. All exterior mortar shall include manufacturer-approved water-repellent additive added to each batch in the appropriate dosage rates for mortar type (M, S or N) per manufacturer's instructions. Refer to NCMA TEK Notes, available at [www.trenwyth.com](http://www.trenwyth.com), for Hot and Cold weather construction practices.

Lay Astra-Glaze-SW+ blocks with the faces level, plumb and true to a line strung horizontally at the glazed face. Install only quality units; reject all defective units, as defined in ASTM C744. Units shall have uniform face joint dimensions of 1/4" both horizontally and vertically. Tool joints neatly after they are finger-hard to make them straight and uniform. Size and place cut pieces appropriately to maintain consistency and bond. Complete masonry construction using procedures and workmanship consistent with the best masonry practices.

### INSTALLATION

**Lighting:** Provide adequate lighting for masonry work by placing all lighting at a reasonable distance from the wall for even illumination. Do not use trough lighting.

**Base Course:** Align base course properly on the floor slab.

**Cove Base:** Keep the cove base tight to the slab if vinyl floor tile is to be installed. For thicker flooring, raise cove base units to the desired height.

**Cutting:** Make all unit cuts, including those for bonding, holes, boxes, etc., with motor driven masonry saws, using either an abrasive or diamond blade. Cut neatly and locate for best appearance.

### MORTAR BEDDING AND JOINTING

1. Lay units with full mortar coverage on head and bed joints taking care not to block cores to be grouted or filled with masonry insulation.
2. Tool all mortar joints when thumbprint hard into a concave configuration.
3. Care should be taken to remove mortar from the face of masonry units before it sets.
4. Tuckpoint the joints of scored units for proper appearance. All exterior scored units must be tuckpointed to prevent water penetration. Rake back the joint when epoxy (Bonsal/Laticrete) is used on select jobs that require better moisture prevention. NO RAKE JOINTS.

Various masonry mortars may be used with Astra-Glaze-SW+ concrete masonry units depending on specific structural requirements for the finished walls. We recommend a matching water-repellent mortar additive (available for purchase from manufacturer). Follow manufacturer's instructions in all mortar applications.

### EPOXY FINISHED JOINTS

In areas exposed to excessive moisture, make sure to tool mortar joints with a minimum of 1/4" and tuckpoint with an approved water-resistant grout. A typical tuckpointing grout is BONSAL® POLYMER MODIFIED SANDED TILE GROUT mixed with the BONSAL B-7000 EPOXY. Do not add water or anything else in addition to the B-7000, which will make it a 100% solid enabling it to be acid and stain resistant.

**Recommendation for using BONSAL® – DO NOT FLOAT GROUT ACROSS GLAZED SURFACE. THE PROPER TECHNIQUE IS TO POINT OR USE A MORTAR GUN!**

### FLASHING OF MASONRY WORK

Install flashing at locations shown in the plans and in strict accordance with the details and the best masonry flashing practices.

### WEEP HOLES AND VENTS

Install weep holes and vents at proper intervals at courses above grade and at any water stops over windows, doors and beams. Consult NCMA TEK Notes, available at [www.trenwyth.com](http://www.trenwyth.com), for additional information on flashing.

### INSPECTION

The glazed facing shall conform to the requirements of ASTM C744 when viewed from a distance of five (5) feet at right angles to the wall with normal lighting. The concrete masonry units on which the glaze is molded shall conform to the requirements of ASTM C90.

### CLEANING

Keep walls clean daily during installation using brushes or rags and a clean damp cloth. Harsh cleaning methods after walls have been erected may mar the surface of the blocks. Do not allow excess mortar lumps or smears to harden on the glazed surfaces. Remove green mortar with a dry cloth. Do not use steel wool, sandpaper or other abrasives.

### FINAL CLEANDOWN

Clean the completed walls with Burnished Custom Masonry Cleaner by PROSOCO 3:1 solution, carefully following manufacturer's washdown instructions — including thorough rinsing. Do not use acid or abrasives on the glazed surfaces.

### MAINTENANCE

Astra-Glaze-SW+ units, properly installed and cleaned, need virtually no maintenance other than routine cleaning with typical non-abrasive household cleaner. Graffiti, paint or dye may need special cleaning methods and products such as Trenwyth Graffiti Wizard® environmentally friendly cleaner. Contact manufacturer for specific cleaning recommendations. Do not powerwash.

### INSTALLATION RECOMMENDATIONS

- For walls with a glazed finish on both sides, use two single-faced units. Because masonry units are typically installed aligning one side, the second side of double faced units is almost invariably misaligned. Double-faced units are not recommended. Manufacturer accepts no responsibility for face alignment.
- Cavity wall construction is recommended for exterior walls, with proper flashing, venting and weep holes.
- For best appearance, use stack bond construction when stack bond appearance is desired (as opposed to scored units in running bond).
- All exterior mortar joints must contain a manufacturer-approved water repellent additive.
- For best appearance and water resistance, tuckpoint scored joints on interior and exterior applications.
- Colored matching or contrasting mortar / epoxy is available when using colorful Astra-Glaze-SW+ units. Contact your Trenwyth representative for information.



This page intentionally left blank

R-values of concrete masonry walls are correlated to concrete density, since thermal conductivity of concrete increases with increasing density. The following tables list a range of R-values for each density. Contact your Trenwyth representative for specific block densities.

**Table 2 — R-Values For 6 in. (152 mm) Concrete Masonry Walls, hr . ft<sup>2</sup>·F/Btu<sup>3</sup>**

Construction	Density of concrete pcf	Cores empty		Cores filled with:							
				Loose-fill insulation				Polyurethane foamed insulation		Solid grouted	
				Perlite		Vermiculite		range	mid	range	mid
				range	mid	range	mid				
Exposed block, both sides	85	2.2-2.5	2.4	4.8-6.1	5.3	4.5-5.6	5.0	5.2-7.0	5.9	1.6-1.8	1.7
	95	2.1-2.4	2.2	4.1-5.4	4.6	3.9-5.0	4.3	4.4-6.1	5.0	1.5-1.7	1.6
	105	2.0-2.2	2.1	3.5-4.8	4.0	3.3-4.5	3.8	3.7-5.2	4.3	1.4-1.6	1.5
	115	1.8-2.1	2.0	3.0-4.2	3.4	2.9-4.0	3.3	3.1-4.5	3.6	1.4-1.5	1.4
	125	1.7-2.0	1.8	2.5-3.7	3.0	2.5-3.5	2.9	2.6-3.9	3.1	1.3-1.5	1.4
	135	1.6-1.9	1.7	2.2-3.2	2.6	2.2-3.1	2.5	2.2-3.4	2.7	1.3-1.4	1.3

**Table 3 — R-Values For 8 in. (203 mm) Concrete Masonry Walls, hr . ft<sup>2</sup>·F/Btu<sup>3</sup>**

Construction	Density of concrete pcf	Cores empty		Cores filled with:							
				Loose-fill insulation				Polyurethane foamed insulation		Solid grouted	
				Perlite		Vermiculite		range	mid	range	mid
				range	mid	range	mid				
Exposed block, both sides	85	2.4-2.7	2.5	6.3-8.2	7.1	5.9-7.5	6.6	6.9-9.4	8.0	1.9-2.1	2.0
	95	2.3-2.6	2.4	5.3-7.2	6.1	5.0-6.7	5.7	5.8-8.1	6.7	1.7-2.0	1.8
	105	2.1-2.4	2.2	4.5-6.3	5.2	4.3-5.9	4.9	4.8-7.0	5.6	1.6-1.9	1.7
	115	2.0-2.3	2.1	3.8-5.5	4.4	3.7-5.2	4.3	4.0-6.0	4.7	1.5-1.8	1.6
	125	1.9-2.2	2.0	3.2-4.8	3.8	3.1-4.6	3.7	3.3-5.1	4.0	1.5-1.7	1.5
	135	1.7-2.1	1.9	2.7-4.2	3.3	2.7-4.0	3.2	2.8-4.4	3.4	1.4-1.6	1.5

**Table 4 — R-Values For 10 in. (254 mm) Concrete Masonry Walls, hr . ft<sup>2</sup>°F/Btu<sup>a</sup>**

Construction	Density of concrete pcf	Cores empty		Cores filled with:							
				Loose-fill insulation				Polyurethane foamed insulation		Solid grouted	
				Perlite		Vermiculite		range	mid	range	mid
				range	mid	range	mid				
Exposed block, both sides	85	2.5-2.9	2.7	7.5-9.9	8.5	7.0-9.1	7.9	8.2-11.3	9.5	2.1-2.4	2.2
	95	2.4-2.7	2.5	6.3-8.7	7.2	6.0-8.0	6.8	6.7-9.7	7.9	1.9-2.2	2.0
	105	2.2-2.5	2.3	5.2-7.5	6.1	5.0-7.0	5.8	5.5-8.2	6.6	1.8-2.1	1.9
	115	2.1-2.4	2.2	4.4-6.5	5.2	4.2-6.2	5.0	4.6-7.0	5.5	1.7-2.0	1.8
	125	1.9-2.3	2.1	3.7-5.6	4.4	3.6-5.4	4.3	3.8-6.0	4.6	1.6-1.9	1.7
	135	1.8-2.1	2.0	3.1-4.9	3.7	3.0-4.7	3.6	3.2-5.1	3.9	1.5-1.8	1.6

**Table 5 — R-Values For 12 in. (305 mm) Concrete Masonry Walls, hr . ft<sup>2</sup>°F/Btu<sup>a</sup>**

Construction	Density of concrete pcf	Cores empty		Cores filled with:							
				Loose-fill insulation				Polyurethane foamed insulation		Solid grouted	
				Perlite		Vermiculite		range	mid	range	mid
				range	mid	range	mid				
Exposed block, both sides	85	2.6-3.0	2.8	9.1-12.1	10.3	8.5-11.0	9.6	10.0-13.8	11.5	2.3-2.6	2.4
	95	2.4-2.8	2.6	7.6-10.5	8.8	7.2-9.7	8.2	8.2-11.8	9.6	2.1-2.4	2.3
	105	2.3-2.6	2.4	6.3-9.1	7.4	6.0-8.5	7.0	6.7-10.0	8.0	2.0-2.3	2.1
	115	2.1-2.5	2.3	5.2-7.9	6.2	5.1-7.4	6.0	5.5-8.5	6.6	1.9-2.2	2.0
	125	2.0-2.3	2.2	4.4-6.8	5.3	4.2-6.5	5.1	4.5-7.2	5.5	1.8-2.0	1.9
	135	1.9-2.2	2.0	3.6-5.8	4.4	3.6-5.6	4.3	3.7-6.1	4.6	1.7-1.9	1.8

Information based on data published by the National Concrete Masonry Association. See NCMA TEK Note 6-2A, available at [www.trenwyth.com](http://www.trenwyth.com).



Additional r-values can be achieved with factory-installed expanded polystyrene, such as Korfil or ICON inserts.

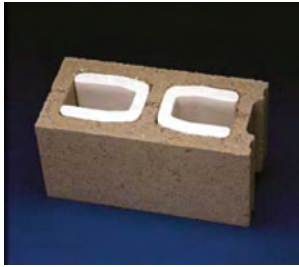

**Korfil® Block Insulation inserts** are individually molded expanded polystyrene inserts. Installed at your Trenwyth manufacturing facility, Korfil insulation inserts are designed to fit standard two-core masonry units. Korfil inserts are available in 6", 8", 10" and 12" widths.



**ICON® Universal Concrete Block Insulation Inserts** are molded from expandable polystyrene. Pre-fit at your Trenwyth manufacturing facility, ICON inserts are designed to compress and fit the core of all masonry units and significantly improve cmu thermal efficiency.

### R-Values

Both Korfil and ICON inserts offer your building the following benefits:

- One-step installation of insulated masonry block saves time and money.
- R-value unaffected by moisture or aging
- Insulated block offers up to a 4-hour fire rating
- Improves dew point and sound transmission resistance
- Offers space for easy installation of utilities within wall
- Flame retardant polystyrene
- Use with single-wythe and cavity wall construction
- No maintenance required
- Available in 6", 8", 10" and 12" widths.

Caution: Expanded Korfil polystyrene should not be exposed to temperatures exceeding 184°F.

Applicable Standards:

- ASTM C578 Specification for Rigid Cellular Polystyrene Thermal Insulation
- ASTM C90 Standard Specification for Loadbearing Concrete Masonry Units

6" Two-Core Masonry Unit				
Block - lbs/ft <sup>3</sup>	Cores Empty		Cores Insulated	
	R <sup>i</sup>	U	R <sup>i</sup>	U
80	2.64	.38	6.45	.16
95	2.42	.41	5.39	.19
105	2.29	.44	4.76	.21
115	2.17	.46	4.21	.24
125	2.05	.49	3.69	.27
135	1.95	.51	3.25	.31

12" Two-Core Masonry Unit				
Density of Block - lbs/ft <sup>3</sup>	Cores Empty		Cores Insulated	
	R <sup>i</sup>	U	R <sup>i</sup>	U
80	3.12	.32	9.38	.11
95	2.83	.35	8.09	.12
105	2.66	.38	7.27	.14
115	2.52	.40	6.51	.15
125	2.38	.42	5.78	.17
135	2.26	.44	5.11	.20

8" Two-Core Masonry Unit				
Density of Block - lbs/ft <sup>3</sup>	Cores Empty		Cores Insulated	
	R <sup>i</sup>	U	R <sup>i</sup>	U
80	2.86	.35	7.74	.13
95	2.61	.38	6.55	.15
105	2.46	.41	5.83	.17
115	2.33	.43	5.17	.19
125	2.21	.45	4.56	.22
135	2.10	.48	4.01	.25

12" Cavity Wall, 4" Outer Wythe, 3/4 Air Space, 8" Two-Core Block				
Density of Block - lbs/ft <sup>3</sup>	Cores Empty		Cores Insulated	
	R <sup>i</sup>	U	R <sup>i</sup>	U
80	4.26	.23	9.14	.11
95	4.01	.25	7.95	.13
105	3.86	.26	7.23	.14
115	3.73	.27	6.57	.15
125	3.61	.28	5.96	.17
135	3.50	.29	5.41	.28

10" Two-Core Masonry Unit				
Density of Block - lbs/ft <sup>3</sup>	Cores Empty		Cores Insulated	
	R <sup>i</sup>	U	R <sup>i</sup>	U
80	3.00	.33	8.52	.12
95	2.73	.37	7.25	.14
105	2.57	.39	6.48	.15
115	2.43	.41	5.76	.17
125	2.31	.43	5.09	.20
135	2.19	.46	4.48	.22

The r-values and u-values are based on information provided by insert manufacturer.

NOVA publications.

For more information, contact your Trenwyth representative or visit [www.cbisinc.com](http://www.cbisinc.com).

ASTM C744 specifies the following tests for pre-faced glazed concrete masonry units		
Cracking and Crazeing	A test to ensure that the units are free from cracking and/or crazing.	<b>Complies</b>
Resistance to Staining and Chemicals	Testing of various chemicals, i.e., detergents, solvents, etc., in concentrations set by ASTM standards and ASTM requirements.	<b>Complies</b>
Adhesion	A test to determine the adhesion of the glazed facing to the block substrate.	<b>Complies</b>
Abrasion	A test to measure the abrasion resistance of the glazed facing.	<b>Complies</b>
Color Change	A test by accelerated weathering apparatus to measure color fading or change.	<b>Complies</b>
Soiling and Cleansability	A test to determine how easily the glazed surface can be cleaned.	<b>Complies</b>
Efflorescence	A test to ensure that unsightly soluble salts do not migrate to the surface when moisture is present.	<b>Complies</b>
Dimensional Tolerances	A test to ensure that variations in the sizes of the blocks in all dimensions are less than 1/16".	<b>Complies</b>
Face Variation	A test to ensure that the glazed facing dimensions do not vary more than 1/16".	<b>Complies</b>
Depth Variation	A test by measurements to ensure that the thickness of the pre-faced block are within 1/16" of the specified size.	<b>Complies</b>
Distortion of Facing	A test by measurements to ensure that the glazed facing is straight, true and in plane within 1/16".	<b>Complies</b>
Surface	A laboratory inspection for quality of the face (no imperfection).	<b>Complies</b>
Flame Spread Index *	A test to determine how much the glazed facing will allow flame to spread in a fire.	<b>Complies</b>
Smoke Development **	A test to determine the amount of smoke given off by the glazed facing in a fire.	<b>Complies</b>
<p>* The test method specified in ASTM E84 is used to determine surface burning characteristics.</p> <p>** In this test, red oak is given a value of 100 and asbestos cement board is given a value of 0 to calibrate the test equipment.</p>		

ASTM C90 specifies the following test for load-bearing concrete masonry units		
Compressive Strength and Moisture Absorbency	A test to ensure that blocks meet strength and moisture requirements and are free of cracks and other defects.	<b>Complies</b>
Canadian Standard CSA-CAN3-A165.3-M85		
Aging and Thermal Shock	A test to ensure that no cracking, spalling, crazing or blistering of the glaze occurs when the unit is subject to cycles of thermal shock at 0° and 93° C.	<b>Complies</b>
Other Tests		
Acid Rain Test	A test to ensure that acid rain does not mar the face of Astra-Glaze-SW+ blocks.	<b>Complies</b>
Diesel Fume Exhaust Test	A test to measure the effect of prolonged diesel fume exhaust on the facing of Astra-Glaze-SW+ blocks.	<b>Complies</b>
Waste Water Treatment Plant Test	A test to ensure that the glazed facing is not affected by chemicals found in waste water treatment plant environments.	<b>Complies</b>
Industry-Specific Testing		
<p>Industry-specific certificate of analysis testing has been completed for Astra-Glaze-SW+ glazed masonry units by Froehling and Robertson, Inc. Laboratories. Astra-Glaze-SW+ units successfully pass chemical and medical agents, steam, fuel and detergent testing in:</p> <ul style="list-style-type: none"> <li>• Veterinary Hospitals &amp; Clinics</li> <li>• Animal Shelters</li> <li>• Power Plants</li> <li>• Machine Shops</li> <li>• Heating Plants</li> <li>• Control Labs</li> <li>• Brewing &amp; Distilling Industries</li> <li>• Wash Rooms &amp; Showers</li> <li>• Laundry Rooms</li> <li>• Dairy Industry</li> <li>• Jails</li> <li>• Meat Packagers</li> <li>• Slaughter Houses</li> <li>• Seafood Industries</li> <li>• Kitchens &amp; Food Preparation Facilities</li> <li>• Dish Washing Bars</li> </ul>		



architectural masonry units

# Block Characteristics Fire Rating Astra-Glaze-SW+®

Fire resistance ratings can be calculated using a method that multiplies the percent of solid material in the concrete masonry unit by the actual thickness (in inches) of the blocks to determine the hourly rating for the type of aggregate used. Contact your Trenwyth representative for specific fire ratings.

### FIRE RESISTANCE RATINGS/MINIMUM REQUIRED EQUIVALENT INCHES

Aggregate Type in The Concrete Masonry Unit	Fire Resistance						
	0.5 Hr.	0.75 Hr.	1 Hr.	1.5 Hr.	2 Hr.	3 Hr.	4 Hr.
Calcareous or siliceous gravel	2.0 in.	2.4 in.	2.8 in.	3.6 in.	4.2 in.	5.3 in.	6.2 in.
Limestone, cinders or slag	1.9 in.	2.3 in.	2.7 in.	3.4 in.	4.0 in.	5.0 in.	5.9 in.
Expanded clay, shale or slate	1.8 in.	2.2 in.	2.6 in.	3.3 in.	3.6 in.	4.4 in.	5.1 in.
Expanded slag or pumice	1.5 in.	1.9 in.	2.1 in.	2.7 in.	3.2 in.	4.0 in.	4.7 in.

Calculating "Equivalent Thickness" is simply determining what the block thickness would be if the same amount of material contained in a hollow unit were re-molded without core holes.

### EQUIVALENT THICKNESS OF CONCRETE MASONRY UNITS (IN INCHES)

Nominal Width (Inches)	Equivalent Thickness		
	Based on Typical Hollow Units (1)	Based on Percent Solid	
		(75% - semi-solid)	(100% - solid)
4	2.68 (73.8%)	2.72	3.625
6	3.09 (55.0%)	4.22	5.625
8	4.04 (53.0%)	5.72	7.625
10	4.98 (51.7%)	7.22	9.625
12	5.77 (49.6%)	8.72	11.625

### CALCULATING ESTIMATED FIRE RESISTANCE EXAMPLE

An 8" hollow masonry wall is constructed of expanded slag units reported to be 53%\* solid. What is the estimated fire resistance of the wall (modular units)?

**Equivalent Thickness = % solid x depth**

**Example: .53 x 7.625 in. = 4.04 inches**

**From Table: 3 hr. Fire Resistance requires 4.0 inches**

\*Percentage solid can be calculated from net area or net volume as determined by ASTM C140 "Methods of Testing Concrete Masonry Units".

(1) Information based on data published by the National Concrete Masonry Association in NCMA TEK 7-1A, available at [www.trenwyth.com](http://www.trenwyth.com).

## WING WALL

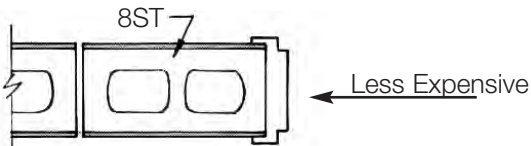
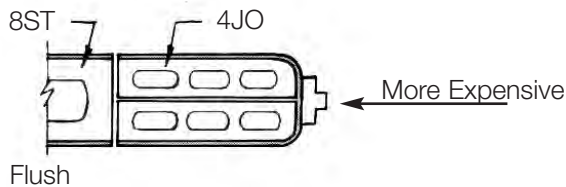

Wrap Around Door Frames.  
Save Two Expensive Shapes.

Use 2" shapes on  
the top and end.

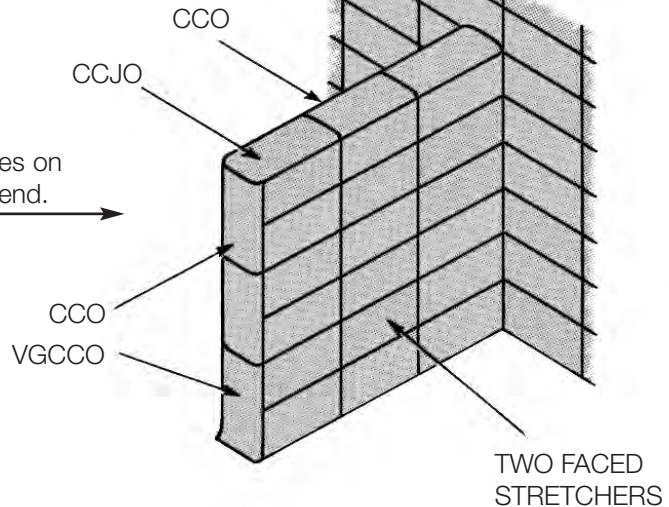

## DOUBLE FACED BLOCKS

An Astra-Glaze-SW+ double faced concrete masonry unit is a single concrete block with a glazed face on both sides. The use of double faced units affords significant cost savings -- walls finished on both sides are completed in a single operation.

PLEASE NOTE THE FOLLOWING LIMITATIONS:

Masons lay block or bricks to one side using a line. This means they are facing one side of the wall when the masonry product is placed and cannot see what the other side looks like. Periodically, the mason can check the opposite side and make slight adjustments -- but not major changes. If units are not aligned properly on the face side of the wall, the error multiplies substantially on the opposite side. This is amplified as the wall length increases. What is rather inconsequential on smaller wall lengths can become significant on longer lengths. Manufacturer accepts no responsibility for face alignment.

With the commonly used methods of laying masonry to one side of a wall, it can almost be assured one side will be better aligned than the other.

Scoring is not recommended for double face units as it will compound any alignment imperfections.



architectural masonry units

## Column Details

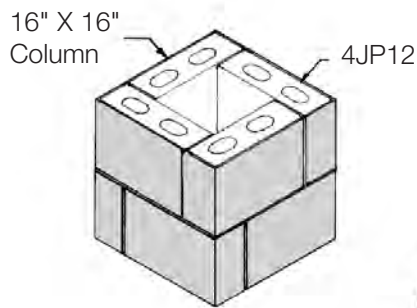

Almost any column size can be made with 4JP12 units.

Eliminates the need for more costly 8JP/JO units.

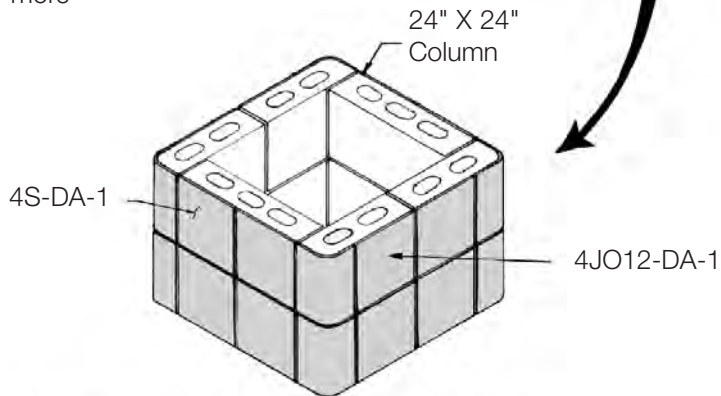

⊘ Use 4JO/JP12s instead of 8JO's

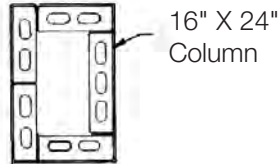
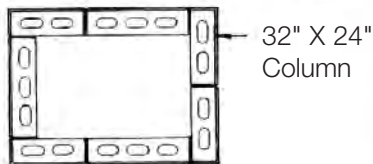

## BOND BEAM

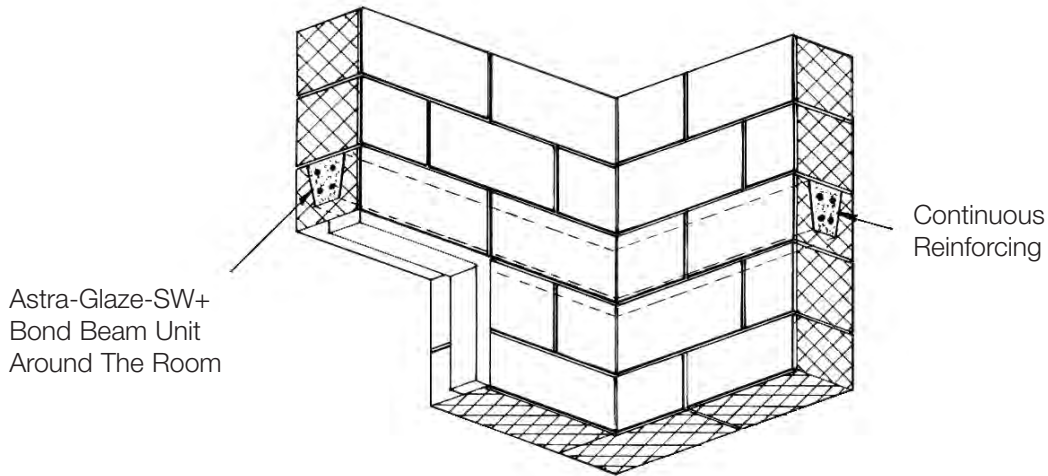

## SCORED JOINTS

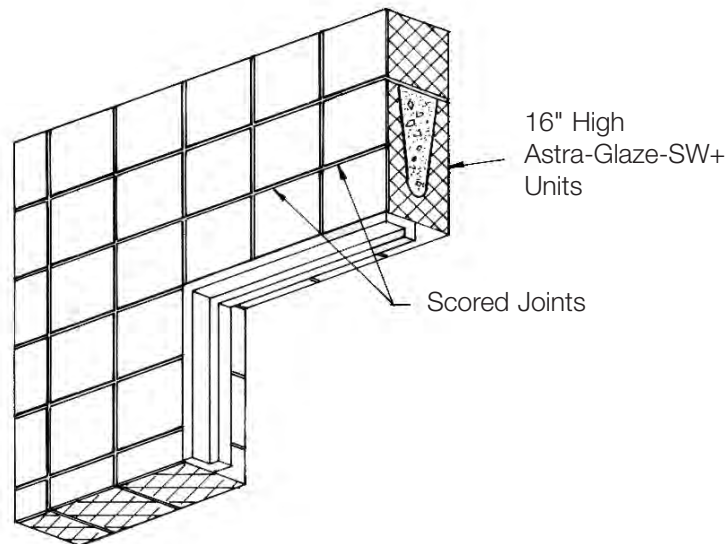





architectural masonry units

### BULLNOSE JAMB MEETING BULLNOSE SILL

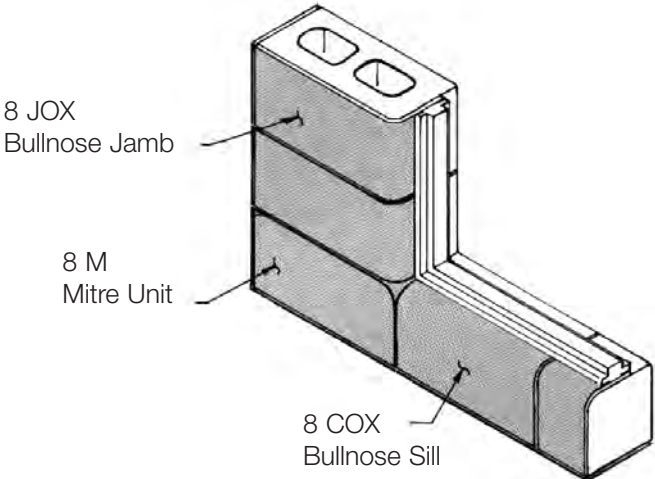

### TYPICAL 135° CORNER

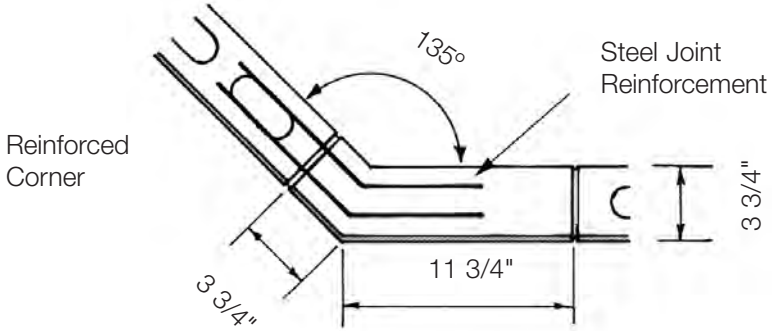

6" Wall Outside  
Corner

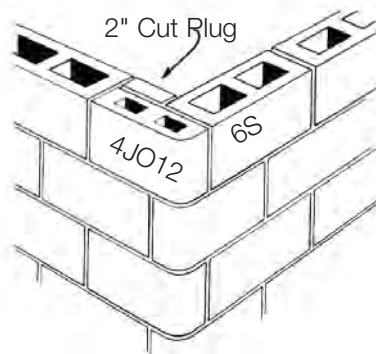

8" Wall Outside  
Corner

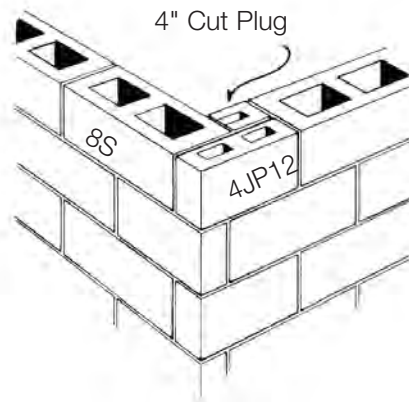

12" Wall Outside  
Corner

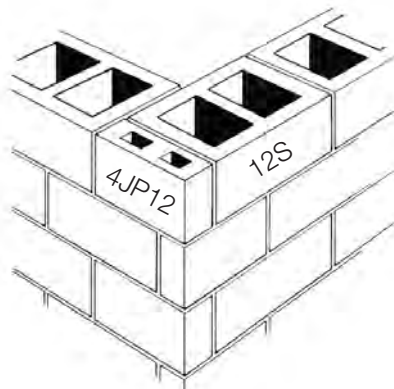



architectural masonry units

# Design Details Astra-Glaze-SW+®

## DOOR AND BASE DETAIL

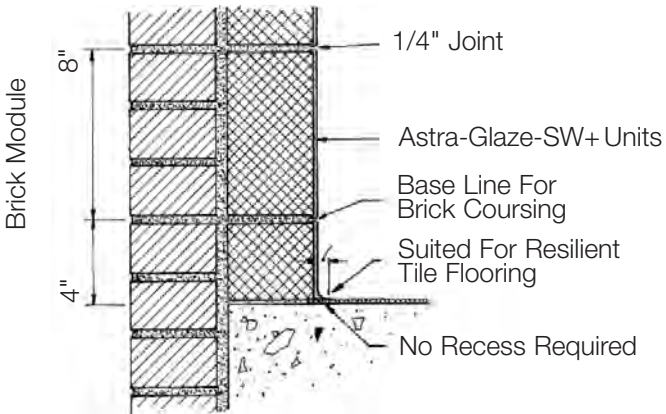
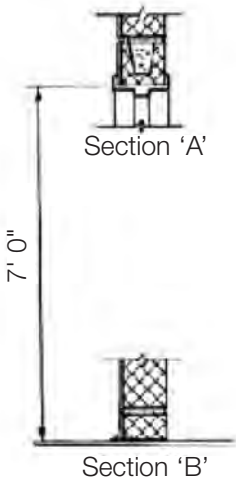
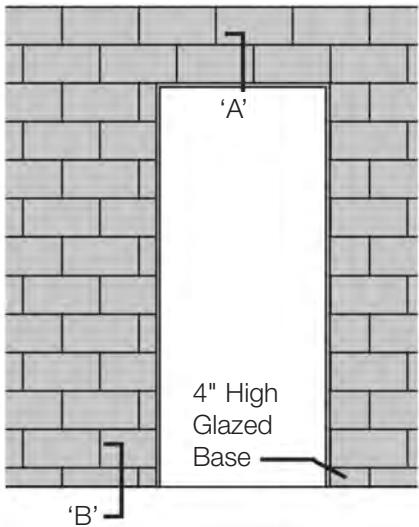

## DOOR AND BASE DETAIL

Using standard Astra-Glaze-SW+ units:

Length of Unit (Inches)	Depth of Unit (Inches)	= Smallest Radius (Without Cutting)	= Overhang* (Inches)
7 5/8	3 5/8	6' 6"	7/64
11 5/8	3 5/8	9' 8"	5/32
7 5/8	7 5/8	8' 0"	3/32
15 5/8	7 5/8	15' 10"	5/32

\*Overhang projection in running bond.

## CURVED MASONRY WALLS

Using Radius blocks:

Standard 12" and 27" Radius Block Corner Detail

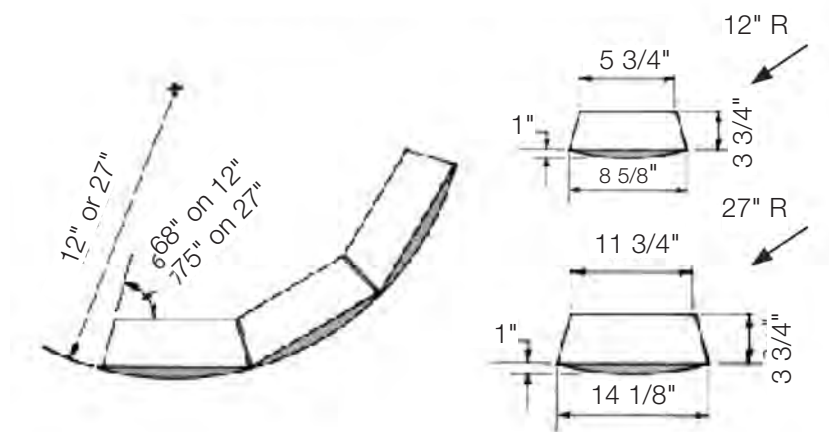

## JAMB UNIT ALTERNATIVES

1. Astra-Glaze-SW+ jamb units are expensive.
2. The elimination of jamb units through the use of wrap-around or flush door frames reduces cost substantially.
3. The use of a 7'2" door with a 7'4" flush frame works well with Astra-Glaze-SW+ units. The 7'2" door can be used with a surface mounted door closer. The increased cost of a 7'2" door (as compared to a 7'0" door) is more than compensated for by the fact that a surface-mounted door closer is less expensive than the internal door closer which is required for shorter doors.
4. Use of the floor to ceiling wrap-around or flush door frames provide a "built-in" control joint for expansion and contraction.

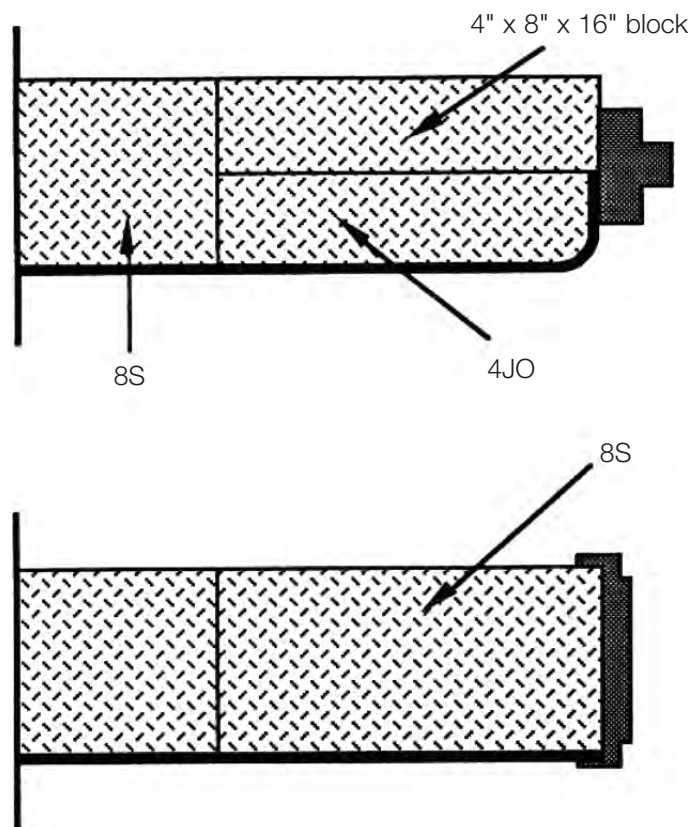

### Recommended Mortars

Various masonry mortars may be used with Astra-Glaze-SW+ concrete masonry units depending on specific structural requirements for the finished walls. Refer to NCMA TEK Notes, available at [www.trenwyth.com](http://www.trenwyth.com), for mortar details.

**For all exterior mortar, use an approved matching water repellent mortar additive** (which may be purchased from manufacturer.) Follow manufacturer's instructions in all mortar applications. Consult manufacturer for recommendations.

### Epoxy Finished Joints

In areas exposed to excessive moisture, make sure to tool mortar joints with a minimum of 1/4" and tuckpoint with an approved water-resistant grout. A typical tuckpointing grout is BONSAL® POLYMER MODIFIED SANDED TILE GROUT mixed with the BONSAL B-7000 EPOXY. Do not add water or anything else in addition to the B-7000, which will make it a 100% solid enabling it to be acid and stain resistant.

**DO NOT FLOAT GROUT ACROSS GLAZED SURFACE AS THIS MAY CAUSE DAMAGE TO THE GLAZED FACE. WHEN USING AN EPOXY GROUT, THE PROPER TECHNIQUE IS TO TUCKPOINT USING A MORTAR GUN OR BAKER'S BAG!**

### Mortar Joints

The proper mortar joint size to use when laying Astra-Glaze-SW+ blocks is 1/4" at the face and 3/8" joints in the concrete block backing.

It is important to realize that the glazed facing overlaps the concrete masonry units and is larger than the block itself. Lay all Astra-Glaze-SW+ units to the face ensuring 1/4" joint measured from the center to center of adjacent edge radii. See below.

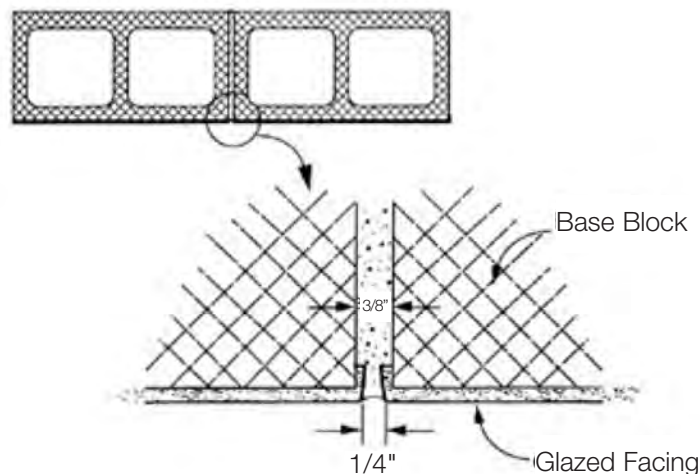



architectural masonry units

# Installation

## Astra-Glaze-SW+®

### IMPORTANT! Before You Begin

Manufacturer requires that you order a full size unit to illustrate color for approval. Manufacturer also requires a sample panel be installed at the jobsite prior to installation of any Trenwyth products. This panel will represent the quality, color and texture of the product and the workmanship to be expected for the project. Either the owner or the project architect must approve the panel. Failure to produce a sample panel may result in loss of warranty. Manufacturer will provide 4" units for a 4' x 4' sample panel at no cost for the material (excluding freight to the site).

### Delivery, Storage and Handling

Glazed masonry units shall be delivered to the jobsite on banded pallets with individual protective covers on each glazed block face. Keep protective block covers on the blocks until installation. Store pallets in single stacks on level ground and cover with waterproof covering (e.g., tarpaulins) to protect the blocks from inclement weather. Handle blocks carefully to avoid breakage and damage to finished surface.

### Project Site Conditions

**Protection of Work:** Cover walls, including open tops, each day after installation to keep open walls protected and dry. After units are installed they should be protected from damage by other trades performing operations that can stain or otherwise damage the finished surfaces by covering walls with plastic. Corners should be protected from damage after installation by covering them with plywood.

Do **not**, under any circumstance, install a damaged unit that does not conform to the requirements of ASTM C90 and ASTM C744 for the block and glazed face respectively. If units have been damaged during transit, contact manufacturer immediately.

### Laying Masonry Walls

Draw blocks from more than one pallet at a time during installation. All exterior mortar shall include an approved water repellent additive added to each batch in the appropriate dosage rates for mortar type (M, S or N) per the manufacturer's instructions. Refer to NCMA TEK Notes, available at

[www.trenwyth.com](http://www.trenwyth.com), for Hot and Cold weather construction practices.

Lay Astra-Glaze-SW+ blocks with the faces level, plumb and true to a line strung horizontally at the glazed face. Install only quality units; reject all defective units, as defined in ASTM C744. Units shall have uniform face joint dimensions of 1/4" both horizontally and vertically and 3/8" on the unglazed side.

Tool joints neatly after they are finger-hard to make them straight and uniform. Size and place cut pieces appropriately to maintain consistency and bond. Complete masonry construction using procedures and workmanship consistent with the best masonry practices.

**Lighting:** Provide adequate lighting for masonry work by placing all lighting at a reasonable distance from the wall for even illumination. Do not use trough lighting.

**Base Course:** Align base course properly on the floor slab.

**Cove Base:** Keep the cove base tight to the slab if vinyl floor tile is to be installed. For thicker flooring, raise cove base units to the desired height.

**Cutting:** Make all unit cuts, including those for bonding, holes, boxes, etc., with motor driven masonry saws, using either an abrasive or diamond blade. Cut neatly and locate for best appearance.

### Mortar Bedding and Jointing:

1. Lay units with full mortar coverage on head and bed joints taking care not to block cores to be grouted or filled with masonry insulation.
2. Tool all mortar joints when thumbprint hard into a concave configuration.
3. Care should be taken to remove mortar from the face of masonry units before it sets.
4. Tuckpoint the joints of scored units for proper appearance. All exterior scored units must be tuckpointed to prevent water penetration. Rake back the joint when epoxy (Bonsal/Laticrete) is used on select jobs that require better moisture prevention. NO RAKE JOINTS.

### Recommended Mortars

**In all exterior mortar, we recommend using the matching manufacturer-approved water-repellent mortar additive** (which may be purchased from manufacturer). Follow manufacturer's instructions. Consult manufacturer for recommendations. See "Mortars and Mortar Joints", Page AG 17.

### Cleaning During Construction

Keep walls clean daily during installation using brushes or rags and a clean damp cloth. Harsh cleaning methods after walls have been erected may mar the surface of the blocks. Do not allow excess mortar lumps or smears to harden on the glazed surfaces. Remove green mortar with a dry cloth. Do not use steel wool, sandpaper or other abrasives.

### Flashing of Masonry Work

Install flashing at locations shown in the plans and in strict accordance with the details and the best masonry flashing practices.

### Weep Holes and Vents

Install weep holes and vents at proper intervals at courses above grade, above flashing and at any water stops over windows, doors and beams. Consult NCMA TEK Notes, available at [www.trenwyth.com](http://www.trenwyth.com), for additional information on flashing.

### Inspection

The glazed facing shall conform to the requirements of ASTM C744 when viewed from a distance of five (5) feet at right angles to the wall with normal lighting. The concrete masonry units on which the glaze is molded shall conform to the requirements of ASTM C90.

### Installation Recommendations

- For walls with a glazed finish on both sides, use two single-faced units. Because masonry units are typically installed aligning one side, the second side of double faced units is almost invariably misaligned. **Use double-faced units only when economy is more important than appearance.**

Manufacturer accepts no responsibility for face alignment.

- Cavity wall construction is recommended for exterior walls, with proper flashing, venting and weep holes.
- For best appearance, use stack bond construction when stack bond appearance is desired (as opposed to scored units in running bond).
- All exterior mortar joints must contain an approved water repellent additive. **In all exterior mortar, we recommend using the matching manufacturer-approved water-repellent mortar additive** (which may be purchased from manufacturer). Follow manufacturer's instructions. Consult manufacturer for recommendations.
- For best appearance and water resistance, tuckpoint scored joints on interior and exterior applications.
- A complementary or matching mortar color is recommended when using colorful Astra-Glaze-SW+ units.

### Grouting Walls Solid

When filling walls with grout, proper detailing to remove moisture is even more critical. Follow masonry best practices and manufacturer's recommendations for the installation of weep holes, vents and flashing.

### Special Shapes and Colors

- **Two different colors on one block.** Any color can be put on one side of the block. And the same or any other color can be put on the other side of the same block.
- **No double bullnose units.** Double bullnose units are not available because they cannot be drawn out of the molds. The molding methods will not accommodate double bullnose units on full-sized blocks. Some double bullnose Astra-Glaze-SW+ units are available in our 1" and 2" Shapes Series.



### Joint Size

The proper joint size to use when laying Astra-Glaze-SW+ block is 1/4" at the face and 3/8" at the unglazed concrete blocking.

The glazed face dimensions are 7 3/4" x 15 3/4", which allows a 1/4" joint using modular coursing.

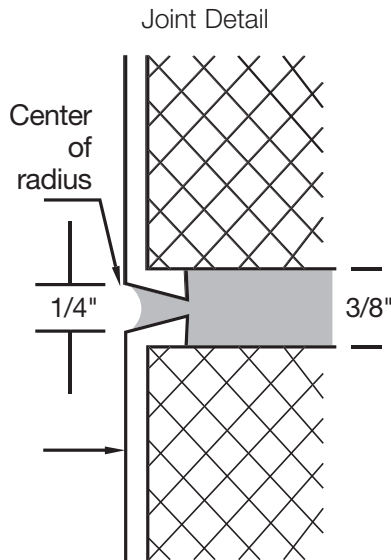

### Installed With Other CMU Products Alignment

If the face of a masonry wall involves different masonry products, it is necessary for the foreman to know the exact dimensions of each of the products to be installed in order to properly make bond when preparing the layout.

If the joint requirement for one of the products is 1/4" and the other is 3/8", this point must be taken into consideration when laying out the first course. If it's not taken into consideration, the resulting finished wall will have unsightly misaligned vertical joints.

### Example:

Astra-Glaze-SW+ units are specified in the wainscot of a corridor with Verastone, Verastone Plus, Trendstone or Trendstone Plus blocks above that point. Units have a single center score and the wall is in running bond.

The difficulty in holding a correct running bond is due to aligning the 3/8" joints of the Verastone,

Verastone Plus, Trendstone or Trendstone Plus units properly over the 1/4" joints of Astra-Glaze-SW+.

Astra-Glaze-SW+ units must be laid using face joints of 1/4" both vertically and horizontally. The Verastone, Verastone Plus, Trendstone or Trendstone Plus units being laid above must be centered over the 1/4" joint of the Astra-Glaze-SW+ units which are already in place.

### Depth Alignment

Astra-Glaze-SW+ units are 1/8" wider than standard CMU's. Astra-Glaze-SW+ double-faced units are 1/4" wider than standard CMU's. This must be taken into consideration in partition and double-faced walls that combine glazed units with other products.

The small ledge created by Astra-Glaze-SW+ blocks combined with other products is very attractive. When the mason lays the walls so that the glazed surface protrudes very slightly beyond the CMU above, it enhances the overall appearance.

An alternative option is to use a 2" glazed unit and a standard-weight block backup. This enables the mason to maintain the same depth of material if desired and guards against moisture retention in the lightweight Astra-Glaze-SW+ block substrate.

PLEASE NOTE: A matching manufacturer-approved water repellent mortar additive must be added to the mortar and built into the adjoining blocks in all exterior applications of Astra-Glaze-SW+ units.



architectural masonry units

## Patching Units Astra-Glaze-SW+®

### Chipped Units

Damaged or chipped units that do not meet requirements of ASTM C90 and ASTM C744 for the block and glazed face, respectively, should not be installed. If units incur damage during installation or by other trades, a patch kit can be ordered from manufacturer. Follow manufacturer's instructions for best results.

Small scratches and scuffs can be repaired using a 50/50 mixture of boiled linseed oil and turpentine mixed well together and applied with a clean rag. After a few minutes, the excess should be removed from the glazed surface with a clean, dry rag or a paper towel. **Be careful not to get this mixture into the joints as it will darken the mortar.**



architectural masonry units

# Cleaning Astra-Glaze-SW+®

## Cleaning

**Walls must be cleaned on a daily basis as block laying proceeds.** Keep walls clean by using brushes or rags and a clean damp cloth. Harsh cleaning methods after walls have been erected may mar the surface of the blocks. Do not allow excess mortar lumps or smears to harden on the glazed surfaces. Remove green mortar with a dry cloth. Do not use steel wool, sandpaper or other abrasives.

## Masonry Cleaners

Use Custom Burnished Masonry Cleaner by PROSOCO (dilute 1 part to 3 parts clean water), carefully following manufacturer's instructions. Available from manufacturer. **Do not powerwash.**

**CAUTION!** The following solvents must never be used as they may damage Astra-Glaze-SW+ block facings: paint remover, lacquer thinner, epoxy thinner, methylene chloride, acetone, muriatic acid.

## General

- Wipe Astra-Glaze-SW+ faces clean with a soft cloth as the blocks are laid each day.
- Wear rubber gloves when using cleaning solutions.
- Test an unexposed portion of adjacent metal fixtures with the cleaning solution. If corrosion or staining occurs, protect the exposed portions.
- Protect adjacent masonry and floor area by saturating with water and flushing away any cleaning solution before it dries.

## Materials

- Two plastic or hard rubber buckets
- Rubber gloves
- Soft fiber masonry brushes (or whitewash brushes)
- Wooden, plastic or other soft, non-staining scraping device
- Supply of "clean" wipers, such as lint-free cloths or paper towels
- Clean water

## Materials (Continued)

- Custom Burnished Masonry Cleaner by PROSOCO. Dilute 1 part to 3 parts clean water.

## DO NOT USE ACID.

## Final Cleandown

### Procedure 1

1. Brush clean water liberally on the surface area to be cleaned. Brush approximately one square yard at a time.
2. **It is important that the glazed wall surface be kept wet at all times.** Do not use dirty water.
3. Apply cleaning solution brushing in a circular motion to remove any unwanted mortar smears.
4. Remove excess lumps of mortar with a wooden, plastic or other soft, non-staining scraping device and re-apply cleaning solution.
5. Allow cleaning solution to remain on the surface for two or three minutes then wash off with liberal amounts of fresh, clean water. **Do not powerwash. DO NOT USE ACIDS.**
6. Wipe wall down **completely dry** with **clean, dry wipers.**

### Procedure 2

If liberal amounts of water cannot be used, an alternative procedure may be employed.

1. Soak a clean wiper in the cleaning solution. Wring it out so it is wet enough to dampen the surface, but dry enough so that the solution will not run down the wall.
2. Allow the solution to remain on the surface for two or three minutes. Remove excess lumps of mortar with the soft scraping device and repeat Step #1.
3. Wipe the wall **completely dry** with **clean, dry wipers.**



architectural masonry units

# Cleaning Astra-Glaze-SW+®

## Maintenance

Astra-Glaze-SW+ units, properly installed and cleaned, need virtually no maintenance other than routine cleaning with standard commercial grade cleaning agents such as PINESOL® or FANTASTIK®. Other detergent-type cleaners, such as MR. CLEAN®, LESTOIL® or equivalent, may be used to remove stains such as grease, paint or pencil. Use clean wipers.

## Graffiti Removal

Graffiti, paint or dye may need special cleaning methods and products such as Trenwyth Graffiti Wizard® environmentally friendly cleaner.

Graffiti Wizard® environmentally friendly cleaner removes most paints and permanent markers, varnish, glue, crayon, oil, grease, food spills, etc. from Astra-Glaze-SW+ glazed surface. Apply Graffiti Wizard using a brush or cloth. Let stand 10 second to 20 minutes, depending on the severity of the stain. If using on a more porous or textured surface, a non-metallic stiff bristle brush may be required. Wipe the surface with a damp cloth. After the stain is removed, neutralize the surface with water making sure that all of the Graffiti Wizard is removed from the surface. Trenwyth Graffiti Wizard is available in 4-oz., 12-oz., 1 gallon and 5 gallon containers. To order, call (800) 233-1924. Always follow manufacturer's safety precautions. **(See Graffiti Wizard® literature, TR2810 behind the General tab.)**

For stubborn stains that are not fully removed with Graffiti Wizard, additional cleaners may be required — specifically Varsol, turpentine or xylene. Extreme caution must be exercised when strong solvents are used to remove paint or other stains from Astra-Glaze-SW+ facings as too much exposure time or rubbing pressure can dull the gloss of the glazed face.

Permanent damage to the glazed facing can result from the use of improper cleaners or solvents. The following solvents must never be used on Astra-Glaze-SW+ block facings: paint remover of any kind, laquer thinner, epoxy thinner, methylene chloride, acetone or muriatic acid.

## Epoxy Grout Removal:

Never allow epoxy grout to fully cure on wall. Fully cured epoxy grout cannot be totally removed from Astra-Glaze-SW+ facings. The following products, however, can remove most of it.

- Denatured alcohol – try this first since it will not damage the glazed face.
- Xylene – CAUTION: Too much exposure time or rubbing pressure can dull the gloss of the glazed face.



architectural masonry units

**Shapes and Sizes Coding System**

All units are nominal 8" and 16" lengths unless modified by symbols as noted below. In some instances, only the first two (2) symbols will be used. Other symbols are added as required.

The coding system is based on a series of symbols that define the size, general type, cap or jamb variance from standard length and return.

- 1. The 1st part is the number denoting the **nominal thickness:**

1", 2", 4", 6", 8", 10" and 12"

- 2. The 2nd part is the letter or combination of letters denoting the general **type of unit.**

S = Stretcher

C = Cap or Sill

G = Cove Base

J = Jamb

T = Two-Faced

V = Vertically Coursed Unit

U = Bond Beam Unit (specify open or solid bottom)

X = Partially Unglazed Face

CC = Capped Both Sides

- 3. The 3rd part is a letter indicating whether the **cap or jamb** unit is bull nose or square. In all cases, this letter immediately follows the symbol describing the type of return unit.

P = Square

O = Bullnose

- 4. The **4th part** is a number denoting **length of the unit** varying from the standard 16" length.

Example: 4CP8 is a 4" thick square corner cap that is 8" long.

- 5. The **5th part** is a letter denoting the hand of the appropriate return unit.

R = Right Hand L = Left Hand

- 6. SPECIAL NOTE: For unit heights varying from the nominal 8", the numeral denoting height immediately follows the numeral denoting thickness.

Example: 84GJO is a nominal 8" thick, 4" high, bullnose, corner, base jamb unit.

- 7. DA# denotes the **scoring pattern.** (See Page AG 28)

### Stretcher

2S

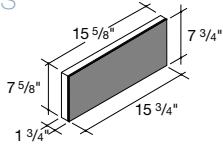

4S

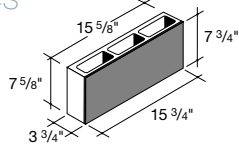

6S

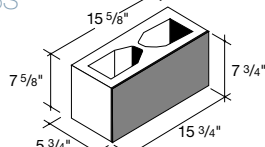

8S

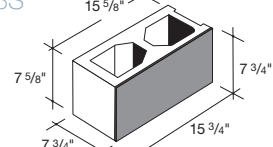

10S

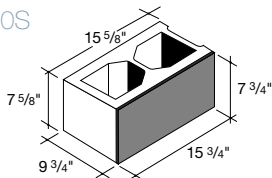

12S

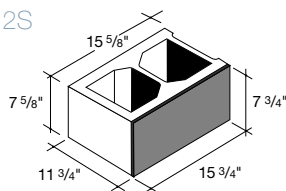

8U

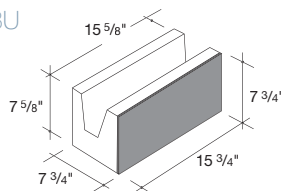

8ST\*\*

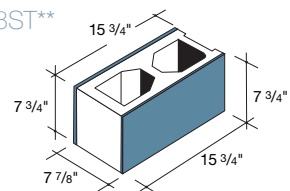

8UT\*\*

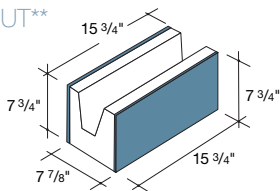

8KOB

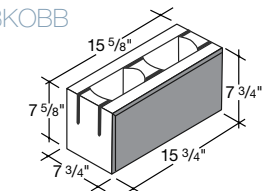

44S

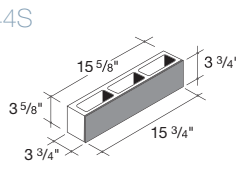

8X

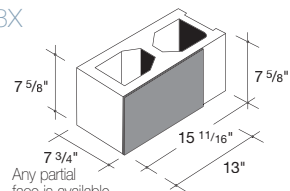

Also available in 4, 6, 10 & 12" thickness.

Also available in 6, 10 & 12" thickness.

Also available in 2, 6, 8, 10 & 12" thickness.

Any partial face is available. Also available in 2, 4, 6, 10 & 12" thickness.

8S8

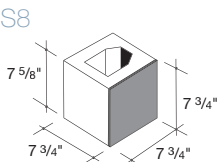

8UCPX

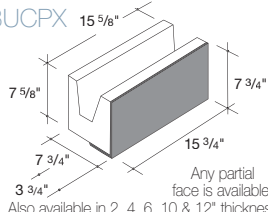

8UCPXT\*\*

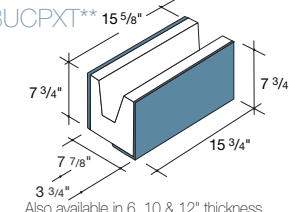

416S

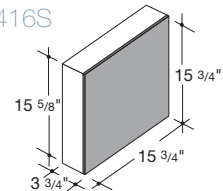

Also available in 2, 4, 6, 10 & 12" thickness.

Any partial face is available. Also available in 2, 4, 6, 10 & 12" thickness.

Also available in 6, 10 & 12" thickness.

412S12

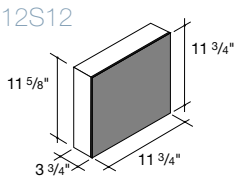

8M-R\*

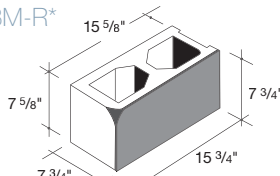

8VU

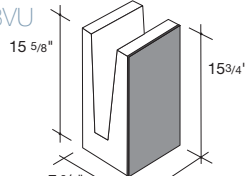

8VUCPPT\*\*

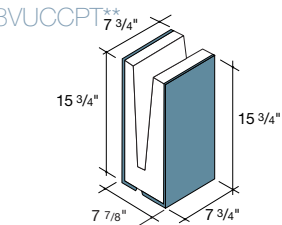

Also available in 2, 4, 6, 10 & 12" thickness.

Also available in 6, 10 & 12" thickness.

### Open Ended Bond Beams (Available from the Phoenix, AZ facility only.)

OE1E

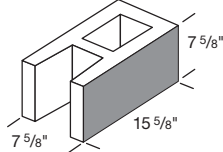

DCBB OE2E

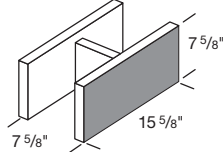

DCBB OE1E

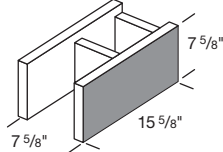

Also available in 4, 6, 10 & 12" thickness.

Note: Not all sizes are shown in this brochure. Please consult your nearest manufacturing facility.

\* Specify left or right (L or R)

\*\* See cautionary note regarding double-faced units in Installation Recommendations on Specifications Page.



architectural masonry units

# Shapes & Sizes Astra-Glaze-SW+®

## Cove Base

4G

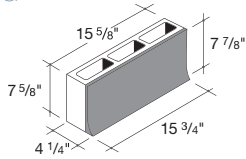

Also available in 2, 6, 8, 10 & 12" thickness.

8G

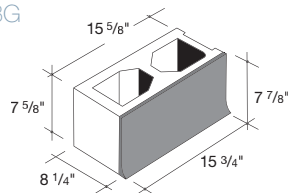

Also available in 2, 4, 6, 10 & 12" thickness.

44G

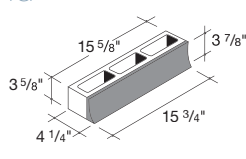

Also available in 2, 6, 8, 10 & 12" thickness.

4GDR\*

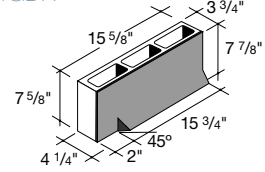

Also available in 2, 6, 8, 10 & 12" thickness.

4GJOR\*

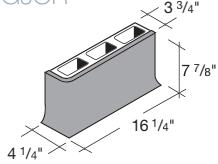

Also available in 2" thickness.

4GJPR\*

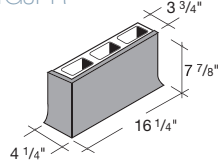

Also available in 2" thickness.

44GJPR\*

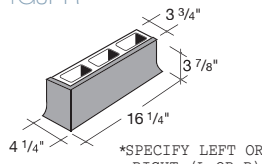

\*SPECIFY LEFT OR RIGHT (L OR R)  
Also available in 2" thickness.

44GJOR\*

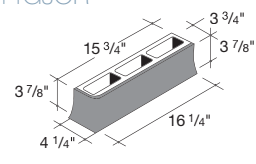

Also available in 2" thickness.

## Jamb

8JO

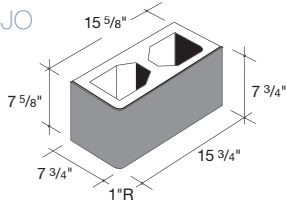

Also available in 2, 4 & 6" thickness.

8JP

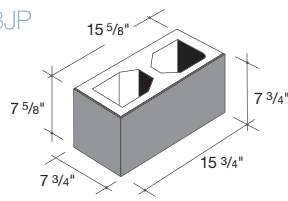

Also available in 2, 4 & 6" thickness.

4JP L CORNER

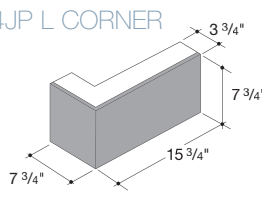

Also available in JO Corner.

8JPX

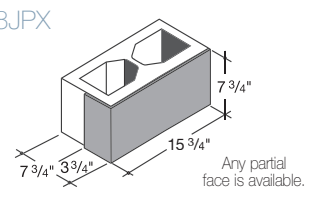

Any partial face is available.  
Also available in 4, 6, 10 & 12" thickness & JO Corner.

416JP

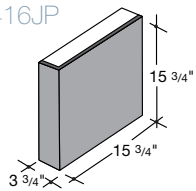

Also available in JO Corner.

412JP12

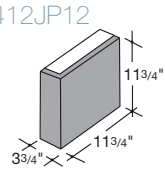

Also available in JO Corner.

4JP135°

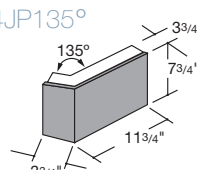

Also available in 6 & 8" thickness.

4JP12

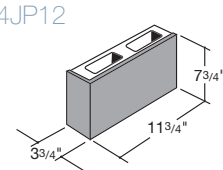

Also available in JO Corner.

4RAD27

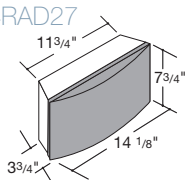

27" Radius Block

\* Specify left or right (L or R)



architectural masonry units

# Shapes & Sizes Astra-Glaze-SW+®

## Metric shapes/sizes are available

See your Trenwyth representative for details on metric shapes and sizes

M20S

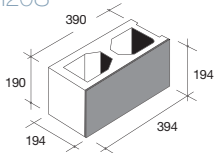

Also available in 5, 10, 15, 25, 35 cm thicknesses

M20G

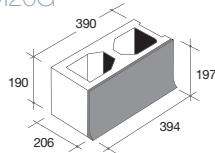

6SM10JP135°

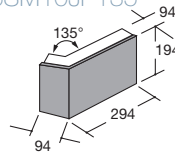

M10CPSL

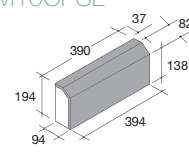

M520CCJO

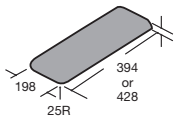

## Caps \*specify left or right (L or R)

4CPSR

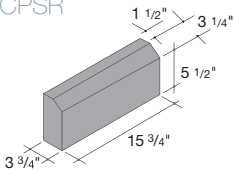

4CPSL

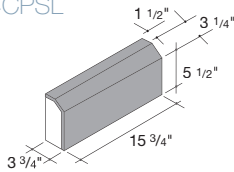

4CP

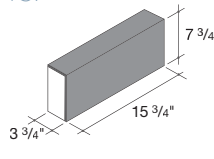

Also available in 2, 6 & 8" thickness.

4CO

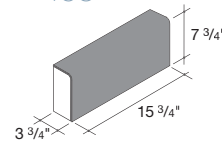

Also available in 2, 6 & 8" thickness.

4CJOR\*

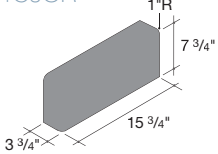

Also available in 2" thickness.

4CJPR\*

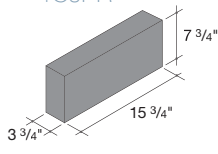

Also available in 2" thickness.

416CJP

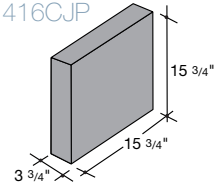

## 1" and 2" shapes series

14CCO or 24CCO

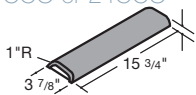

16CCO or 26CCO

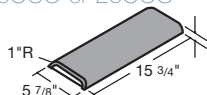

18CCO or 28CCO

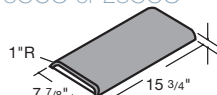

14CCJO or 24CCJO

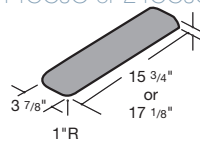

16CCJO or 26CCJO

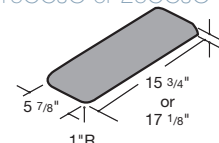

18CCJO or 28CCJO

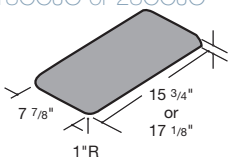

14VGCCO or 24VGCCO

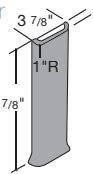

1/2" toe matches standard "G" base units

16VGCCO or 26VGCCO

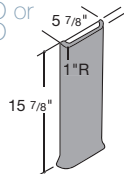

18VGCCO or 28VGCCO

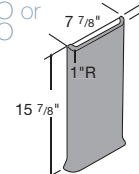



- **Score Dimensions.** The width of the score on the Astra-Glaze-SW+ face is 1/4" and it is cut after the glazed face is molded.
- **Score on the backside of block.** The unglazed back side of Astra-Glaze-SW+ blocks can be scored. The score, however, is 3/8" wide which is standard for raw blocks.
- **Tuckpoint and scored joints.** All scored joints must be tuckpointed to prevent moisture penetration and to match the real joints between the blocks. This gives a more realistic, pleasing appearance to the finished wall.
- **Special scoring.** Written dimensions and a sketch are required in order to produce special scoring. Limitations: No more than five (5) vertical scores or two (2) horizontal scores are acceptable on the face of a block. **DO NOT USE RAKE JOINTS unless tuckpointing with epoxy.**

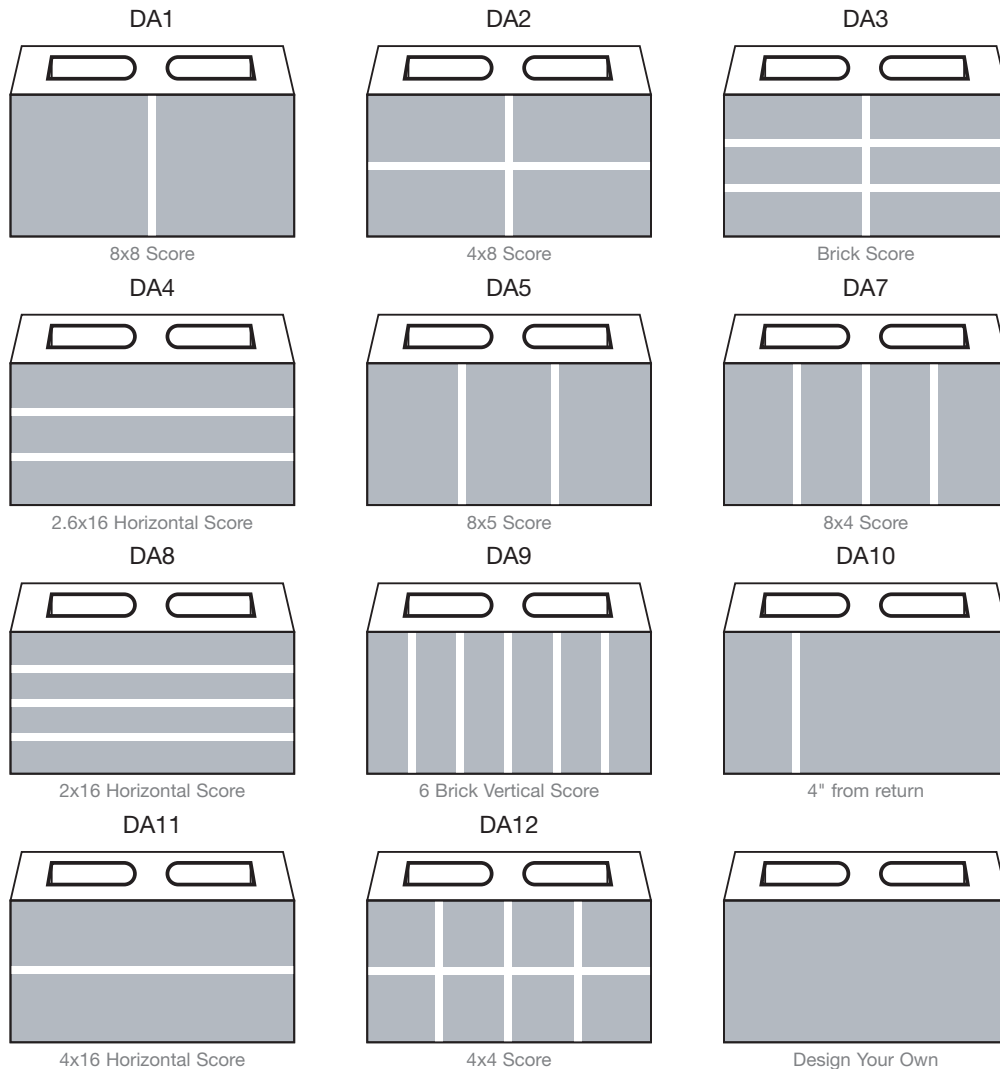



architectural masonry units

# Frequently Asked Questions

## Astra-Glaze-SW+®

### FREQUENTLY ASKED QUESTIONS

#### 1. **How and where is this product made? Is it made like ceramic tile?**

Astra-Glaze-SW+ units are manufactured in Emigsville, Pennsylvania, and Phoenix, Arizona. They are produced using high purity, natural grain silica sands and a resinous binder cast onto a concrete block in a thermoset, glazing process. The result is a hard glazed tile-like surface permanently molded onto one or more faces of the concrete blocks. Astra-Glaze-SW+ blocks are fired at about 500 degrees Fahrenheit in a tunnel oven. Conversely, ceramic tiles are fired at about 2,000 degrees Fahrenheit.

Because Astra-Glaze-SW+ facings are permanently molded to concrete blocks, they cannot come off without destruction to the concrete block itself. Ceramic tile, on the other hand, is a thin fragile layer that is glued on by tile setters after the wall has been erected and can be removed more easily.

#### 2. **Can Astra-Glaze-SW+ blocks be used on the exterior of buildings? Will they deteriorate, fade, crack or spall?**

Astra-Glaze-SW+ units have been used to construct interior and exterior walls of buildings in almost every part of the continental United States for more than 32 years with excellent results.

Important Note: As with any building material, it is important that the building design and workmanship be correct. For example, if the units are laid in the wall such that the concrete block substrate is continually saturated with moisture (in the winter months in northern climates) due to inadequate flashing or coping, poor mortar joints, leaking water pipes, etc., then the constant freezing and thawing action can eventually cause crazing. Of course cracking, due to settling or wall movement can also allow large amounts of moisture to enter and saturate the concrete blocks, causing the same problem. Good masonry building practices and workmanship (including well tooled joints) should be specified and enforced. Proper specification and installation of flashing, coping and weep holes are essential to satisfactory performance and adequate control joints or other devices to accommodate wall movement should be employed. The recommendations of NCMA TEK Notes should be followed. The glazed facings of Astra-Glaze-SW+ and units are unaffected by acid rain or by temperatures up to 400° F.

#### 3. **How do Astra-Glaze-SW+ units perform in extreme cold, heat (i.e. kitchens near grills), sunlight or acid rain, etc.?**

Astra-Glaze-SW+ blocks perform excellently in a wide range of wall applications including kitchens, laboratories, chemical plants, etc. and in the presence of acid rain.

#### 4. **Do the Astra-Glaze-SW+ facings meet Federal Agriculture (i.e. Department of Agriculture) Standards for food processing, etc.?**

Astra-Glaze-SW+ facings meet all federal, state and local standards for chemical resistance, stain resistance, fire, flame, smoke, etc. The federal specification is ASTM C744. It meets the Department of Agriculture standards for meat-packaging plants and other food-processing plants.

#### 5. **What does the "SW" stand for in Astra-Glaze-SW+?**

SW stands for SEVERE WEATHER. Astra-Glaze-SW+ units are a product of state-of-the-art technology and advances in polymer chemistry that have enabled Trenwyth to make its quality products even better.

To withstand all weather conditions from northern hard freeze to southern intense sunlight (UV), the manufacturer's block glazing chemistry has been designed to accommodate both extremes and everything in between.

A degree of ductility has been built into the Astra-Glaze-SW+ facings and only fully cured, completely dry lightweight blocks conforming to ASTM C90 are used for glazing, thereby giving the finished Astra-Glaze-SW+ units exceptional resistance to cracking and crazing. Glazed units manufactured in Arizona are medium weight units. Ultraviolet light inhibitors and stabilizers are built into the Astra-Glaze-SW+ chemistry, allowing the facings to maintain their color. All units contain a manufacturer-approved integral water repellent CMU admixture at the time of manufacture. The backup block is integrally damp-proof preventing water from being absorbed and held behind the glazed facing. If moisture does get into an Astra-Glaze-SW+ wall, the water is not absorbed by the block but is shed, flowing down the wall to be collected by the flashing and directed to the exterior through weeps or vents.

Colorfastness has been achieved through chemistry that blocks ultraviolet light from penetrating the facing and stabilizes the polymers. This prevents degradation of the Astra-Glaze-SW+ facing.

**6. What does the “+” stand for in Astra-Glaze-SW+?**

Astra-Glaze-SW+ glazed masonry units have always been a low maintenance product. Reformulated to be even more graffiti-proof, Astra-Glaze-SW were reintroduced as Astra-Glaze-SW+ units. New built-in protectants in the PLUS units act as an invisible shield that withstands spray paint, permanent markers, grease and crayon.

**7. Are Astra-Glaze-SW+ blocks toxic?**

No. Astra-Glaze-SW+ facings are classified as non-toxic. The only standard for toxicity is the New York City Material and Equipment Acceptance Division (MEA) toxicity requirement. We have passed this standard. Our approval number is MEA 31-82-M.

**8. What are industry standards for glazed blocks, ASTM, etc.?**

The ASTM standard for glazed concrete blocks is ASTM C744.

**9. Are they “UL” rated?**

Astra-Glaze-SW+ blocks are tested annually to Underwriters Laboratories (UL) equivalent standards by various independent testing laboratories. Therefore, they are UL rated although they are not UL listed. There is no requirement that glazed blocks be UL listed in the United States.

**10. Can special colors be made?**

We can match virtually any color.

**11. How is your color consistency and will it match if we do a later addition?**

We match our color standards to very close tolerances. Add orders or additions to older installations can be matched if we are provided with a sample.

As with any manufactured item, a minor variation in shade is to be expected. With Astra-Glaze-SW+ units, we have reduced this to a minimum. The color of the Astra-Glaze-SW+ surface is required to conform to an approved standard, tested and verified by a spectrophotometer.

**12. Can we get two different colors on one block?**

Yes, we can put any color on one side and the same or any other color on the other side of the same block.



architectural masonry units

## Frequently Asked Questions

### Astra-Glaze-SW+®

#### **13. Can special sizes and/or shapes be made?**

We can make a variety of unique sizes and shapes. Additional shapes and sizes can be produced, for an additional fee.

#### **14. Can you provide double bullnose units?**

We cannot provide double bullnose units because they cannot be drawn out of the molds: the molding methods we use will not accommodate double bullnose units on full sized blocks. We do, however, supply some double bullnose units in our 1" and 2" Shapes Series.

#### **15. Why can't two faces and one end be glazed?**

We cannot glaze two faces and one end because it would be impossible to draw such a finished product out of the mold. We can only make one face and an end or we can make one face, one end, and one top, but we cannot make two faces and one end.

#### **16. Can special scoring be done?**

Special scoring can be done. We require a sketch or written dimensions in order to produce the special scoring. There are certain limitations, however, and we generally don't advise more than five vertical scores and not more than two horizontal scores on any face of any block. We have difficulty scoring around bullnose comers and caps. This is very expensive and time consuming but it can be achieved. Check with customer service or your sales representative to make sure that the special scoring patterns you require are feasible.

#### **17. What is the width of the score and is it cast or cut?**

The width of the score on the Astra-Glaze-SW+ face is 1/4" and it is cut after the glazed face is molded.

#### **18. Can I get the back side of the exposed block scored to match the scoring on the glazed face side?**

The back side of the blocks can be scored to match the face. This score, however, is 3/8" wide which is standard for raw blocks.

#### **19. Do I tuckpoint the scored joints?**

All scored joints must be tuckpointed to prevent moisture penetration and to match the real joints between the blocks. The result is a more realistic, appealing finished wall. **DO NOT USE RAKE JOINTS** unless tuckpointing with epoxy.

#### **20. Can I have an Astra-Glaze-SW+ face on one side and a Trendstone finish on the other side of the same block?**

No, an Astra-Glaze-SW+ and Trendstone finish cannot be on the same block because of differences in block density. We will not cast Astra-Glaze-SW+ facings onto heavyweight or normalweight blocks. Astra-Glaze-SW+ facings must be molded onto lightweight or mediumweight blocks to get a strong and integral bond. The surface of heavyweight blocks is generally less open, preventing a good mechanical bond between the facing and the block. Therefore, heavyweight blocks do not stand up very well to freezing and thawing in exterior applications. Lightweight blocks perform well in freeze/thaw conditions because the aggregate used (expanded shale or expanded clay in our case) is cellular in nature, providing a good measure of ductility.

**21. How do Astra-Glaze-SW+ blocks compare to structural glazed facing tile (SGFT); are there any advantages or disadvantages?**

SGFT is available in Standard 8W Series which provides no fire rating or in 8WC PR Series which gives a one (1) hour fire rating for a 4" wall. The fire rated units are priced so high as to be noncompetitive with Astra-Glaze-SW+ units.

Standard 8W SGFT units are competitive with Astra-Glaze-SW+ units in the 2" and 4" thicknesses but are much higher priced in 6" and 8" thicknesses (and in the fire rated units mentioned above) and are not available at all in 10" or 12" thicknesses.

Having a vitrified, ceramic glazed surface, SGFT is slightly more chemical and stain resistant than Astra-Glaze-SW+ units. However, like china, it is much more brittle and more easily damaged by impact. And unlike the smooth, even finish of Astra-Glaze-SW+ units, SGFT surfaces tend to distort during manufacturing, resulting in a wavy look when installed. Additionally, the color consistency has traditionally been poor.

**22. How do you patch Astra-Glaze-SW+ units?**

Contact customer service for an Astra-Glaze-SW+ Patch Kit. Small scratches and scuffs can be removed by using a 50/50 mixture of boiled linseed oil and turpentine mixed well together and wiped on with a clean rag. After a few minutes the excess should be removed with a clean dry rag or a paper towel. Be careful not to get this mixture into the joints as it will darken the mortar.

**23. How do I cut Astra-Glaze-SW+ blocks in the field? Are there special tools required? Will the surface splinter and chip when cutting?**

Most of the shapes and sizes are produced as needed. Cutting should be done only when absolutely necessary. It is best to cut Astra-Glaze-SW+ blocks with a motor driven power masonry saw using a wet diamond blade. There are some dry diamond blades that perform acceptably without cooling water. There are also abrasive blades that can be used in these power saws. The glazed surface will not splinter and chip if care is exercised and the above recommendations are followed.

**24. How well does the product withstand graffiti and how is it removed?**

The Astra-Glaze-SW+ surface withstands graffiti very well. Graffiti can generally be carefully removed using Trenwyth's Graffiti Wizard® environmentally friendly cleaner (see Page TR2810).

**25. What do I use for the washdown?**

See Astra-Glaze-SW+ Cleaning Instructions in (Pages AG 22–23).

**26. What type of mortar can be used?**

Astra-Glaze-SW+ blocks should be laid in a full bed of mortar which is consistent with the best concrete masonry practices carefully following the recommendations of NCMA TEK Notes for best results. All exterior mortar shall include a Trenwyth-approved integral water repellent additive added to each batch in the appropriate dosage rates for mortar type (M, S or N) per manufacturer's instructions.

**27. Can I return blocks I don't use?**

No. All Astra-Glaze-SW+ blocks are custom made to order. We require a signed Sales Contract before we will start manufacturing any order. Since we don't make any blocks for stock, any Astra-Glaze-SW+ blocks that are ordered in excess must be taken and cannot be returned. It is strongly recommended that great care be taken with "take-offs" to avoid this problem.



architectural masonry units

# Frequently Asked Questions

## Astra-Glaze-SW+®

### 28. Can a face be supplied without a block attached to it?

No, we cannot supply a face without a block attached to it. The minimum thickness of block we can make is a 2" unit and that can usually be used in any thin veneer situation.

### 29. Will the face pop off (typical of glazed brick)?

The Astra-Glaze-SW+ face will not pop off. The face is an integral part of the block once it has been molded and cannot be removed without destruction of the basic block.

### 30. How do we deal with the "ledge" created by Astra-Glaze-SW+ blocks when painted Concrete Masonry Units are laid above (i.e. walls with glazed wainscot)?

The 1/8" ledge created by Astra-Glaze-SW+ blocks in such an application is actually very attractive. If the mason lays the walls so that the glazed surface protrudes 1/8" beyond the painted CMU above, it can actually enhance the overall appearance. Conversely, the units can be laid flush to the face if the ledge is not desired. (Then the 1/8" protrusion will be at the back of the wall.)

### 31. Can any mason install this product?

Masons who are used to laying architectural blocks can lay glazed blocks very well. Unfortunately, no matter how well our blocks are manufactured, if they are not laid well, the appearance of the project is diminished. Astra-Glaze-SW+ must be laid to the face.

### 32. Can water go through the Astra-Glaze-SW+ face?

No, the face of the Astra-Glaze-SW+ units is impervious to water. Tests have been conducted using a high-pressure stream and no measurable penetration was recorded. All blocks used for glazing contain Trenwyth-approved water repellent additive to provide additional protection should water penetrate the wall through the mortar joints. Note: Any scores on the face of Astra-Glaze-SW+ blocks must be tuckpointed or water will, of course, penetrate through the scores.

### 33. Why choose Astra-Glaze-SW+?

• Highest standard for quality	• Pre-consumer recycled content (upon request)
• The advantages of block construction	• Tremendous variation of color, pattern and design
• Prompt delivery from large, efficient regional plants	• Tight impervious surface for sanitary environments
• Finished load-bearing walls	• Fire protection built into your design
• One trade installation cost savings	• Personalized service
• Custom color matching capabilities	• Available in Acousta-Wal sound-absorbing units

Modern technology has created many new building materials with properties and performance characteristics never before obtainable in so called "natural" materials — Trenwyth Astra-Glaze-SW+ units are an example of such progress.

Recent improvements in technology allow for the stain-resistant, chemical resistant, non-fading and fire resistant structural glazed masonry units which are manufactured today under the trademark Astra-Glaze-SW+®.

**Channels of Distribution:** Astra-Glaze-SW+ units are manufactured at two locations in the United States and distributed through regional sales offices and a network of dealers throughout the United States, Canada and the UK. Most of the Astra-Glaze-SW+ dealers are large block manufacturers or brick distributors serving every part of the U.S.

**High Quality Standards:** There is one uniform, high standard for all Astra-Glaze-SW+ units — Grade A1. There are no seconds, no unselected grades, no off-grade industrial classification. Just Grade A1!

**Variety to Meet Your Design Needs:** Consider the first advantages of the unit itself — the surface is a smooth satin finish available in 96 Standard colors plus custom colors. The 8" x 16" face size means approximately one unit per square foot. Face sizes are exact and permit precise coursing and uniform 1/4" joint size. Face modulation is negligible. This gives a smooth, even appearance to the glazed wall surface. Astra-Glaze-SW+ facings are available on virtually every size and shape of concrete block (for example, cove base, jamb, bond beam, cap units, etc.). This allows a wide latitude and flexibility in design and methods of construction.

In addition to the usual glazed shapes and trim units, Astra-Glaze-SW+ brings to the designer the Scored Series and the Design Series which offer a wide selection of scale and pattern. The Scored Series provides the choice of reduced scale and pattern with the economy of large 8 x 16 block, e.g. 8 x 8 Score (DA 1) 5 x 8 Score. (DA5) Brick Score (DA3), etc.

The Design Series includes various curved and flared projections on the faces to give form to the wall.

**Cost Savings:** The economies inherent in Astra-Glaze-SW+ construction become very clear when you analyze the erection of a loadbearing wall.

In the case of ceramic tile, the mason lays up the block wall and another tradesman, the tile setter, lays up the ceramic tile in a separate operation and, in a further operation, grouts the joints. In the case of epoxy coating, the mason lays up the block wall then another tradesman, the painter this time, applies a filler coat plus two finish coats.

Astra-Glaze-SW+ units, however, are laid up by the mason in one operation providing both the structural wall and the finished surface. Furthermore, Astra-Glaze-SW+ facings are permanent. They will last the life of the building, will not fall off or ever require resurfacing. No matter what thickness of loadbearing wall, the masonry contractor can lay one through-wall unit with Astra-Glaze-SW+ units.

**Ease of Construction:** In modern construction, today's designer is faced with a host of problems involving electrical conduits, gas pipes, water pipes, waste stacks and other utilities running through the building. In schools, hospitals, laboratories and industrial plants, a designer may have to deal with compressed air lines, oxygen systems, etc. as well.

Plumbing, wiring, gas pipes and waste stacks are easily accommodated in Astra-Glaze-SW+ walls. The Astra-Glaze-SW+ finish is easily drilled or sawed to receive the electrical plumbing or other outlets.

**Fire Safety:** Truly adequate fire protection with a factor of safety is of vital concern to every designer of schools, hospitals, dormitories and multi-story buildings. Astra-Glaze-SW+ units give you that required fire rating up to 4 hours, which is the rating of the block itself.

The glazed facing itself is classified as non-burning. The ASTM and Federal government Specifications allow a flame spread of up to 25 and a smoke contribution of 50. Astra-Glaze-SW+ tests at 5 flame spread and 25 smoke contribution. This means that our glazed unit greatly exceeds the requirements for fire safety.



TRENWYTH®

architectural masonry units

## Frequently Asked Questions Astra-Glaze-SW+®

**In Summary:** Astra-Glaze-SW+ offers you prompt delivery from large efficient regional plants and personalized service. You get the cost savings of a single unit being both structural and finished. The glazed finish meets the highest standard for quality — and exceeds all industry standards. Astra-Glaze-SW+ units bring all the advantages of block construction with tremendous variation of color, pattern and design. With Astra-Glaze-SW+ units, the entire back-up wall can be eliminated. Important, too, is the fact that you provide recognized fire protection in your design.

If you have any questions, please contact your sales representative or customer service at 800-233-1924 to find the representative in your area.





architectural masonry units

# Colors Astra-Glaze-SW+®

Ask about our custom color matching capabilities.

Note: Please specify from actual sample.

\*LRV – Light Reflectance Value

	Cool Cream 51.8%		Terra Cotta 13.5%		Soft Rose 16.5%		Silver Gray 46.3%		Valley Forge Blue 9.4%		Sunbath 56.5%
	Vanilla 53.6%		Vivid Red 7.8%		Chelsea Pink 25.5%		Pewter 21.1%		Cosmic Blue 8.8%		Avocado 21.4%
	Buttermilk 51.8%*		Garnet 8.4%		Ruby Red 9.5%		Earl Grey 9.5%		Ultra Blue 5.4%		Mountain Meadow 26.7%
	Wheatfield 41.8%		Russett 12.6%		Orchid Petal 36.8%		Charcoal 6.3%		Frosted Jade 19.8%		Willow Leaf Green 10.4%
	Lemon Peel 47.6%		Chili Pepper 10.5%		Lavender 26.2%		Ebony 3.8%		Island Green 36.2%		Ivory 50.7%
	Golden Honey 51.1%		Peach Fuzz 40.6%		Royal Purple 17.3%		Pastel Blue 42.8%		Misty Green 45.7%		Antique Lace 38.5%
	Sunflower 35.4%		Orange Cream 42.1%		Snow White 66.4%		Baby Blue 36.3%*		Silk Green 46.7%		Safari Beige 34.8%
	Deep Marigold 31.5%		Burwick Blush 48.6%		Whitman White 61.5%		Rothwell Blue 22.8%		Caribbean Reef 21.3%		Sand 34.8%
	Coral Flower 44.7%		Cherokee Tan 29.6%		Egg Shell 54.0%		Fountain Blue 20.7%		Riviera 17.9%		Coastline 26.3%
	Desert Rose 40.8%		Warm Spice 16.1%		Oatmeal 51.4%		Azure Breeze 18.2%		Teal 7.7%		Pebble 27.3%
	Light Sienna 23.7%		Canella 18.3%		Green Speckle 50.7%		Diamond Blue 11.0%		Sea Green 19.4%		Clay 28.5%
	Sedona Clay 29.8%		Mahogany 12.3%		Custom Red 52.3%		Rich Blue 12.6%		Mallard Green 15.4%		British Fog 21.0%
	Paprika 29.4%		Autumn Brown 11.6%		Custom Blue 52.3%		Cobalt Blue 18.1%		Rain Forest 16.2%		Dark Granite 18.1%
	Viking Red 17.0%		Copperstone 8.9%		Custom Speckle 50.7%		Bimini Blue 23.2%		Shamrock Green 14.2%		Peanut Brittle 23.0%
	Fire Engine Red 9.5%		Coffee Bean 4.6%		Cappuccino 32.3%		Sapphire 11.4%		Holly Green 11.1%		Wild Mushroom 11.2%
	Banner Red 14.5%		Pink Ice 52.4%		Custom Gray 51.2%		Ocean Blue 21.5%		Moss Green 5.1%		Flint 8.2%

This page intentionally left blank